

Multi-Channel Isolation
Protection

Support Modbus RTU Protocol
over RS485 Serial Port

Used Widely in Industrial
Automation Control Systems

Remote I/O Module Data Acquisition Module DAM102 ~ DAM124 Series

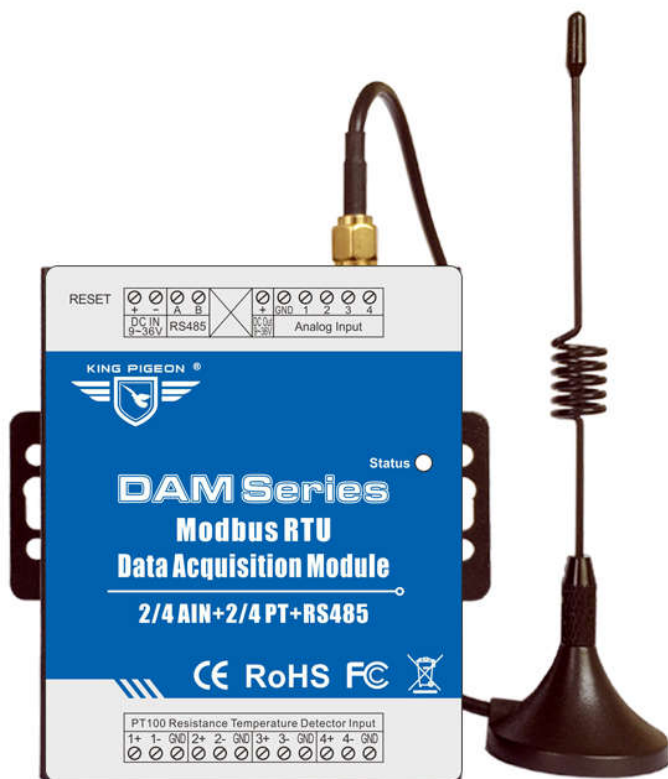

DAM102~DAM124 User Manual

Ver 1.0

Date Issued: 2017-07-01

King Pigeon Hi-Tech. Co., Ltd.

www.GPRS-M2M.com



Table of contents

1.	Brief introduction -----	3
2.	Safety Directions -----	3
3.	Standard Packing list -----	3
4.	Mainly Features -----	3
5.	Physical Layout and Installation Diagram-----	4
6.	Initialize/Reset the GSM unit -----	6
7.	Settings & Operations-----	7
8.	Register Table List -----	10
9.	Warranty -----	10

This handbook has been designed as a guide to the installation and operation of DAM Series. Statements contained in the handbook are general guidelines only and in no way are designed to supersede the instructions contained with other products.

We recommend that the advice of a registered electrician be sought before any Installation work commences. King Pigeon Hi-Tech.Co., Ltd, its employees and distributors, accept no liability for any loss or damage including consequential damage due to reliance on any material contained in this handbook.

【UPGRADE HISTORY】

DATE	FIRMWARE VERSION	HARDWARE VERSION	DESCRIPTION



Model List

I/O Model	Digital		Analog Input	Temperature
	Input	Output		
DAM102	2			
DAM108	4			
DAM104		2		
DAM110		4		
DAM106	2	2		
DAM112	4	4		
DAM114			2	
DAM116			4	
DAM118				2
DAM120				4
DAM122			2	2
DAM124			4	4

DIN: Digital input, Compatible with NC/NO/Pulse Counter/TTL;
DOU: Relay output, Max: 3A/240VAC, Compatible with NC/NO/Pulse Counter/TTL;
AIN: Default: 4~20mA, 12 Bits ,Isolated; Optional:0~20mA/4~20mA/0-5V/0~10V;
Temperature: PT100,PT500, PT1000,CU50,CU100 or other PT Resistance Thermometer;
Protocol: Modbus RTU, with RS485 interface, *RS232 is optional;
Dimension: 70*88*30mm, support DIN RAIL Optional.

1. Brief introduction

The DAM with multi-channel for digital input, analog input, digital output (relay), analog output, and temperature inputs. It can work with any RTU, SCADA, data monitoring, data loggers, PLC's, process controllers, instrumentation that supports Modbus RTU Protocol over RS485 serial port. and transmit in ASCII data format to engineering units for control equipments. It is an industrial class, high reliability, low-power consumption, high stability and high precision control module. Powered up by 12VDC or 24VDC.

The DAM is used widely as an extension control module in of Base Transceiver Station, diesel generator rooms, engine room, transformer substations, telecommunication equipment rooms, power supply systems and so on.

The DAM with metal box, support standard 35mm DIN rail makes it easy to install in fields.

Tips: King Pigeon Hi-Tech.Co.,Ltd not only provides competitive prices, excellent quality but also helps customers to solve technical problems, improve quality, reduce extra costs, and assist customers to become more competitive. If our existing modules cannot meet your requirements,

we also design and manufacture new models / products according to buyer's request. Any of your requirements is always welcome!

Typically applications:

Server room, Warehouse, Drug store, Medicine center, Seafood storage, Aquarium, Supermarket, hospital, Hotel; Weather Stations remote control and data logging, Transformer stations, BTS room, agriculture, Supervision and monitoring alarm systems, etc.

2. Safety Directions



Safe Startup

Do not use the unit when using GSM/3G/4G equipment is prohibited or might bring disturbance or danger.



Interference

All wireless equipment might interfere network signals of the unit and influence its performance.

3. Standard Packing List

DAM X 1; User Manual X 1.

Note: The package does not include any sensors and adapter.

Optional: 35mm Standard DIN rail fixed Bracket

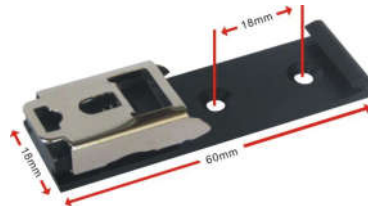

4. 1Mainly Features

- Power supply with reverse polarity connection protection;
- 32 bit MCU, reliable performance with in-built watchdog;
- Support relay outputs, 7A@125VAC, 5A@125VAC, 20A@14VDC; (DAM104/110/106/112 Only)
- LEDs for status indication makes it easy to program in filed;
- Support configure parameters, load/export profiles via PC;
- Wall mount or 35mm standard DIN rail Design, convenient installation,
- Metallic cover, small size, exterior dimension is L70*W88*H30mm.



4. 2 Specifications

Item	Reference Scope
DC Power Supply	Standard Adapter: DC 12V/1A Range 9~36VDC
Power Consumption	Standby:12V/50mA; WorkingMax.:12V/150mA Typically ≤3W
Communication Protocol	Modbus RTU
Modbus Address	1~247
Data Format	n,8,1; e,8,1; o,8,1 or n,8,2
Communication Interface	RS485
Baud Rate	1200, 2400, 4800, 9600, 115200 Bps
Output Response Time	100~200mS
Operation Temperature	-20~70℃;
Isolated Type	Input / Power / RS485 Serial port isolated
Exterior Dimension	70*88*30mm
Installation	35mm standard DIN rail(Optional) Wall mount (Default)
Net Weight	500g

5. Physical Layout and Installation Diagram

5.1 DAM Unit physical layout

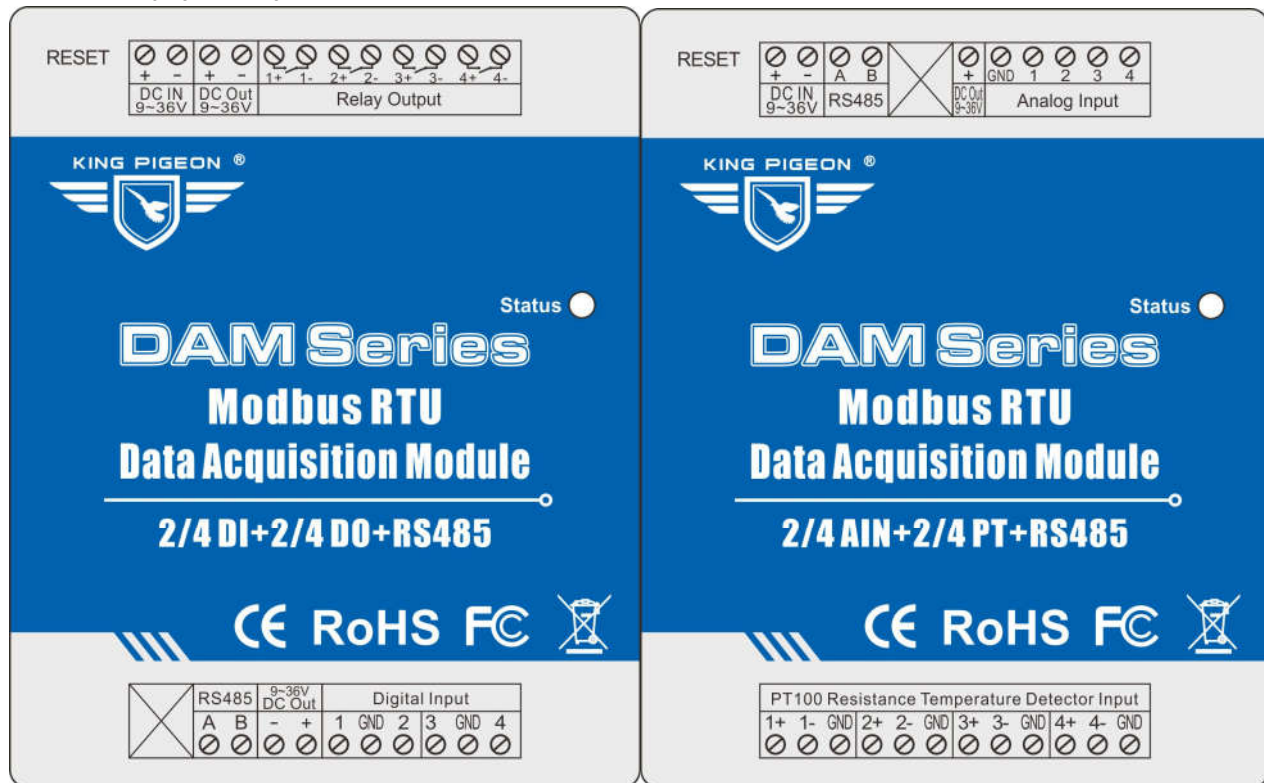

LED Indicator Instruction

Status



ON :Standby;
Flash: Data Transmission;
OFF: Power off.

5.2 Interface Instructions for installation

1) Connect External DC Power and Temperature & Humidity Sensor

See below interface, please connect to the correct wires.

Interface Instruction		
DC IN 9~36V	+	DC9~36V positive input, 1.5A, for power on the Unit;
	-	DC9~36V negative input, 1.5A, for power on the Unit;
DC Out 9~36V	+	DC9~36V positive output, 1.5A
	-	DC9~36V negative output, 1.5A
Relay Output	1+	Relay output 1;
	1-	Relay output 1;
	2+	Relay output 2;
	2-	Relay output 2;
	3+	Relay output 3;
	3-	Relay output 3;
	4+	Relay output 4;
	4-	Relay output 4;
RS485	A	RS485 A Port, used it to communicate with the device for Data Transfer
	B	RS485 B Port, used it to communicate with the device for Data Transfer
Digital Input	1~4	Digital input 1~4, connect to one wire of the wired Detector
	GND	Ground point; connect to another wire of the wired Detector
Analog Input	1~4	Analog input 1~4, the data wire of the analog transducer
	GND	Ground point; connect to GND wire of the analog transducer
PT100 Resistance Temperature Detector Input	1+	Data Wire of the PT100
	1-	
	GND	GND , Connect to PT-100 GND wire, (black wire or white wire)
	2+	Data Wire of the PT100
	2-	
	GND	GND , Connect to PT-100 GND wire, (black wire or white wire)
	3+	Data Wire of the PT100
	3-	
	GND	GND , Connect to PT-100 GND wire, (black wire or white wire)
	4+	Data Wire of the PT100
	4-	
	GND	GND , Connect to PT-100 GND wire, (black wire or white wire)

2) Connect electrical device to Relay outputs.

The DAM unit (**DAM104/110/106/112 Only**) provides some relay outputs; it can be used for control different device according to requirements. The connection diagram is below:

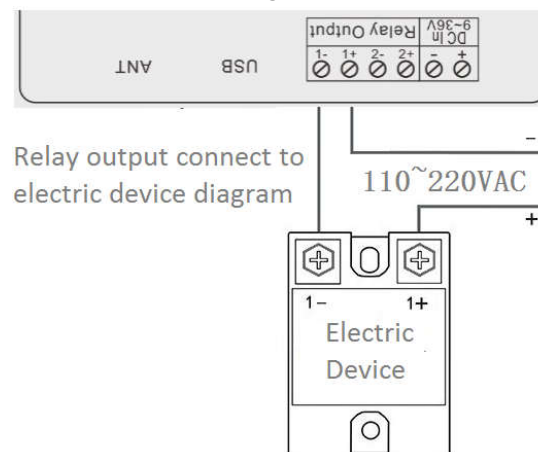

3) Connect to the PT-100 Temperature Sensor.



The DAM unit (**DAM118/120/122/124 Only**) provides some resistance temperature input; it can be used for monitoring the temperature according to requirements.

6.1 Initialize/Reset the DAM unit

The Unit can be reset to factory default once mistake programmed. Please follow below steps to initialize it. After initialized, the parameters will set as factory default.

- 1) Power on the Unit
- 2) Press and hold the RESET button for 5 seconds,;
- 3) Loose the RESET Button.
- 4) When the status LED flashing, then Reboot the unit then recovery to factory default settings, and will enter to work mode.

6.2 Testing the DAM unit

- 1) **Please refer to the above mentioned wiring connection to finish the connection.**

Please only power on the DAM unit before you're sure the connection are correct.

After connected to the power, the Status LED indicator will ON.

- 2) **Default setting: Address 1, baud rate 9600bps, data format: n,8,1.**

Users can change the settings by configuration software.

- 3) **Connect to RS485 interface.**

The host should provide the RS485 interface, if no RS485 port, please use the RS232 to RS485 converter. We recommend the user use the isolated RS485 to improve the reliability.

In the RS485 interface, all of the A+ should connect together, and the B- connects together, too. Also, the GND should connect together then connect to the Communication GND.

The RS485 network usually allow to connect maximum 32 device. if the device more than 32, then please use the RS485 repeater to extend it. The RS-485 network should use the shield twist cable, the shield should connect to GND independently.

The RS485 network communication distance maximum is 1200m, when the communication baud rate is high will cause the communication distance short, in this case, please use the RS485 repeater.

At the end of the RS485 network, if the communication quality is not good then usually should connect a 120~300Ω/0.25W termination resistors. If the communication quality is good then no need to connect this resistor.

7. Settings & Operations

The DAM is user-friendly design. The user can setup it by the PC Configuration through RS485/232 interface, the communication protocol is Modbus RTU, for the Register Address, please refer to **Chapter 8**.

Tips!

- 1) *Please power on to check the LEDs status according to above mentioned LED Definitions, keep switch on it during the programming.*
- 2) *The PC Configuration in the CD, please click it to run it. Also can download from www.GPRS-M2M.com under DAM page directly.*



Start to Configure:

Step1: Install the Configurator

The Configurator in the CD or download from www.GPRS-M2M.com, then installs it on the computer.

Step2: Connection

Please only power on the DAM unit before you're sure the connection are correct.

Step3: Connect the DAM to the PC by RS485/232/USB Cable. And connect the external DC Power to DC Power Ports, Power on, and switch on the device, see below:

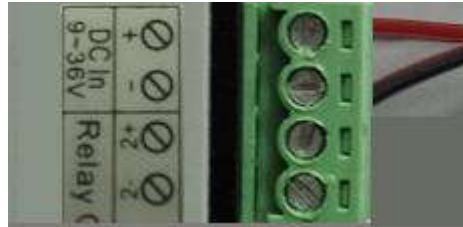

Step4: Install RS485/232/USB Driver

Install the Driver to the computer. When successful, it can be found out at the device manager of the XP or Windows 7 or Win8/Win10. Also, please download the driver from the Supplier website of the RS485/232/USB cable.

Step5: Run the Configurator (Compatible with Windows XP/7/8/10)

Tips: In some computer, it required download net framework 4.0 while installation, then please click "Yes" to go to Microsoft website to download this service pack.



Step5: Choose the correct "COM port", then click "open Com port", and select the model number or search the model automatically, after that, then can start to programming.

8. Modbus Register Tables: (The register is used for the Modbus RTU protocol)

8.1 Modbus Register Tables for DAM104/110/106/112:

Table 1: Digital output definition, function code 01/05/0F

Address	Definition	Data Description
0000H	DO1	1 st digital output: = 1 triode close, = 0 open.
0001H	DO2	2 nd digital output: = 1 triode close, = 0 open.
0002H	DO3	3 rd digital output: = 1 triode close, = 0 open.
0003H	DO4	4 th digital output: = 1 triode close, = 0 open.

Table 2: Digital Input definition, function code 02

Address	Definition	Data Description
0000H	DI1	1 st digital input, = 0 (0~0.5VDC) short/close, = 1 (3~30VDC) Open/no signal.
0001H	DI2	2 nd digital input, = 0 (0~0.5VDC) short/close, = 1 (3~30VDC) Open/no signal.
0003H	DI3	3 rd digital input, = 0 (0~0.5VDC) short/close, = 1 (3~30VDC) Open/no signal.
0004H	DI4	4 th digital input, = 0 (0~0.5VDC) short/close, = 1 (3~30VDC) Open/no signal.

Remark: If the digital input=0, it means closed, if digital input=1, it means open or no signal.



Table 3: Holding register definition, function code:03/10H

Address	Definition	Data Description
9C40H	Mod	Device Model number
9C41H	Ver	Version
Above mentioned items are READ ONLY, below mentioned items can READ and WRITE.		
9C42H	ADDR	Device Address; 1~247; 0 is the broadcast address.
9C43H	COM1	COM setting: high-order 8 bytes reserved. The low-order bytes low 3 bytes baud rate: 0:115200; 1:57600; 2:38400; 3:19200; 4:9600; 5:4800; 6:2400; 7:1200 The lowest 3rd~7th bytes in the low-order bytes is data format: 00 stands for 10bits,equal to n,8,1; 50 stands for 11bits, Even-parity check: e,8,1; 58 stands for 11bits, Odd Parity Check: o,8,1; 20 stands for 11 bits, non parity, 2 is stop bit,n,8,2; default is 4, equal to 9600bps. (9600, 8.N.1)
9C44H	DO1-PUL	DO1 output type control: BIT15=1 : Pulse Output control; BIT15=0 : TTL. Low-order 8 byte: Pulse Width(time): 1~250 = 0.1~25.0 seconds; Default value: 10 (one second)
9C45H	DO2-PUL	DO2 output type control, detail description as same as above DO1.
9C46H	DO3-PUL	DO3 output type control, detail description as same as above DO1.
9C47H	DO4-PUL	DO4 output type control, detail description as same as above DO1.
9C48H	DI Pulse Counter	Low-order 4 byte is the Pulse Counter: BIT0=1, Enable the DI1 as a Pulse Counter, =0: Disable BIT1=1, Enable the DI2 as a Pulse Counter, =0: Disable BIT2=1, Enable the DI3 as a Pulse Counter, =0: Disable BIT3=1, Enable the DI4 as a Pulse Counter, =0: Disable
9C49H	Function for Power Failure	Low-order 2 byte is the additional function when the power failure: BIT0=1: Save the pulse counter value; BIT0=0 : Don't save the pulse counter value; BIT1=1 : Keep the relay status; BIT1=0 : Don't keep the relay status.

Address	Definition	Data Description
9C4AH 9C4BH	DI1_Cnt	1 st DI 32 bytes pulse counter; 4 bytes, MSB first
9C4CH 9C4DH	DI2_Cnt	2 nd DI 32 bytes pulse counter; 4 bytes, MSB first
9C4EH 9C4FH	DI3_Cnt	3 rd DI 32 bytes pulse counter; 4 bytes, MSB first
9C50H 9C51H	DI4_Cnt	4 th DI 32 bytes pulse counter; 4 bytes, MSB first



8.2 Modbus Register Tables for DAM118/120/122/124:

Table 1: Holding register definition, function code:03/06/10H

Address	Definition	Data Description
9C40H	Mod	Device Model number
9C41H	Ver	Version
9C42H	AdVal[1]	1 st PT100 ADC_Value ,range:0-65535, for adjust the temperature
9C43H	AdVal[2]	2 nd PT100 ADC_Value ,range:0-65535, for adjust the temperature
9C44H	AdVal[3]	3 rd PT100 ADC_Value ,range:0-65535, for adjust the temperature
9C45H	AdVal[4]	4 th PT100 ADC_Value ,range:0-65535, for adjust the temperature
9C46H	AdVal[5]	1 st AIN ADC_Value , range:0-65535, for adjust at site
9C47H	AdVal[6]	2 nd AIN ADC_Value , range:0-65535, for adjust at site
9C48H	AdVal[7]	3 rd AIN ADC_Value , range:0-65535, for adjust at site
9C49H	AdVal[8]	4 th AIN ADC_Value , range:0-65535, for adjust at site
9C4AH	AI1	The 1 st Analog Input: 1. If enable the Max/Min, then will calculate the real value of the sensors. 2. If there is no Max/Min: a) 0~10000 correspond to 0~10V b) 0~10000 correspond to 0~5V c) 0~10000 correspond to 0~20mA d) 0~10000 correspond to 4~20mA
9C4BH	AI2	2 nd Analog Input, detail description as same as above AI1.
9C4CH	AI3	3 rd Analog Input, detail description as same as above AI1.
9C4DH	AI4	4 th Analog Input, detail description as same as above AI1.
9C4EH	PT1	1 st channel for measuring the temperature, unit :0.1℃ Int, the actualvalue=DATA/10, unit:℃
9C4FH	PT2	2 nd channel for temperature, detail description as same as above PT1.
9C50H	PT3	3 rd channel for temperature, detail description as same as above PT1.
9C51H	PT4	4 th channel for temperature, detail description as same as above PT1.
Abovementioned items are READ ONLY, below mentioned items can READ and WRITE.		
9C52H	ADDR	Device Address; 1~247; 0 is the broadcast address.
9C53H	COM1	COM setting: high-order 8 bytes reserved. The low-order bytes low 3 bytes baud rate: 0:115200; 1:57600; 2:38400; 3:19200; 4:9600; 5:4800; 6:2400; 7:1200 The lowest 3rd~7th bytes in the low-order bytes is data format: 00 stands for 10bits,equal to n,8,1; 50 stands for 11bits, Even-parity check: e,8,1; 58 stands for 11bits, Odd Parity Check: o,8,1; 20 stands for 11 bits, non parity, 2 is stop bit,n,8,2; Default is 4, equal to 9600bps. (9600, 8.N.1)
9C54H	AIMode1	Analog input model1 setting, low-order 2 bytes 0:0-5V; 1:0-10V; 2:0-20mA ;



		3:4-20mA; Highest order byte b7=1 is enable the Max/Min; 0= disable
9C55H	AIMode2	AIN 2 Setting, as same as the AIMode1
9C56H	AIMode3	AIN 3 Setting, as same as the AIMode1
9C57H	AIMode4	AIN 4 Setting, as same as the AIMode1
9C58H	AdMax1	AIN1 Max Range, default: 5000
9C59H	AdMax2	AIN2 Max Range, default: 5000
9C5AH	AdMax3	AIN3 Max Range, default: 5000
9C5BH	AdMax4	AIN4 Max Range, default: 5000
9C5CH	AdMin1	AIN1 Min Range, default: 0
9C5DH	AdMin2	AIN2 Min Range, default: 0
9C5EH	AdMin3	AIN3 Min Range, default: 0
9C5FH	AdMin4	AIN4 Min Range, default: 0
9C60H	Pt_0C[1]	1 st PT100 input calibrated values in 0°C Remark: To testing the PT100 in 0°C, or connect to a 100R resistance to get the ADC_Value, then use this value to adjust the accuracy, Default:4500
9C61H	Pt_0C[2]	2 nd PT100 input calibrated values in 0°C
9C62H	Pt_0C[3]	3 rd PT100 input calibrated values in 0°C
9C63H	Pt_0C[4]	4 th PT100 input calibrated values in 0°C
9C64H	Pt_50C[1]	1 st PT100 input calibrated values in 50°C 1 st PT100 input calibrated values in 50°C Remark: To testing the PT100 in 50°C, or connect to a 100R resistance to get the ADC_Value, then use this value to adjust the accuracy.
9C65H	Pt_50C[2]	2 nd PT100 input calibrated values in 50°C
9C66H	Pt_50C[3]	3 rd PT100 input calibrated values in 50°C
9C67H	Pt_50C[4]	4 th PT100 input calibrated values in 50°C

Remark: If the PT100 temperature sensor cannot measuring the correct value, then need to adjust it, for 0 °C (Pt_0Cx) and 50 °C (Pt_50Cx) .

9. Warranty

- 1) This system is warranted to be free of defects in material and workmanship for one year.
- 2) This warranty does not extend to any defect, malfunction or failure caused by abuse or misuse by the Operating Instructions. In no event shall the manufacturer be liable for any alarm system altered by purchasers

The End!

Any questions please help to contact us feel free.

[Http://www.GPRS-M2M.com](http://www.GPRS-M2M.com)